

ITEM: SURFACE MOUNT TURNBUCKLE

MATERIAL: TYPE 316 STAINLESS STEEL.

FITTING TYPE: ADJUSTABLE CABLE END TURNBUCKLE FOR ATTACHING & TENSIONING LINES.

SWAGE TYPE: MACHINE HEX SWAGE AT FACTORY (1/8" & 3/16" SIZES ALSO AVAILABLE IN CABLECRIMP HAND SWAGE STYLE FOR ATTACHING IN THE FIELD).

POST TYPE: WOOD. METAL POSSIBLE BUT NOT RECOMMENDED. (POSTS NOT INCLUDED).

FASTENING TO POST: ATTACH TO FACE OF END/TERMINATION POST OR WALL USING TWO SCREWS OR BOLTS.

FASTENING AT ANGLES: TURNBUCKLE MOUNTING FLANGE PIVOTS UP TO 130 DEGREES.

CABLE TENSIONING: ADJUST BY TURNING TUBULAR TURNBUCKLE BODY.

HARDWARE PAIRINGS: USUALLY PAIRED WITH FIXED SURFACE MOUNT OR ANOTHER SURFACE MOUNT TURNBUCKLE. MAY ALSO USE ANY OTHER TENSION ADJUSTMENT FITTING OR FIXED END.

SUPPLIER: FEENEY, INC.

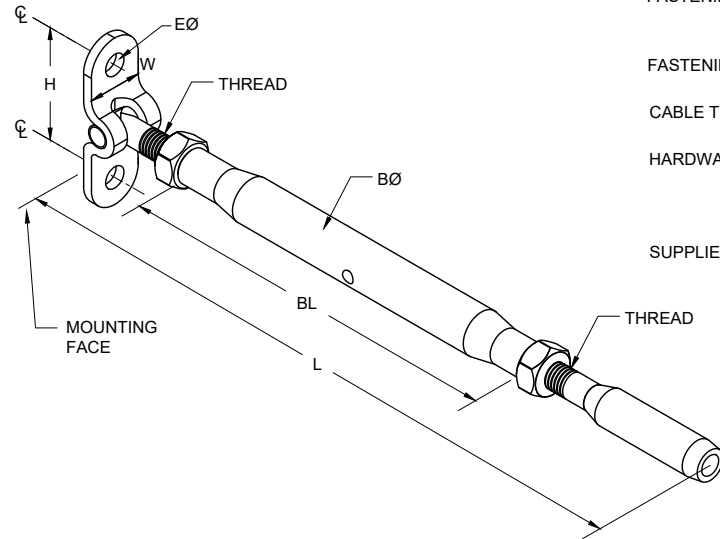

SURFACE MOUNT TURNBUCKLE, STAINLESS STEEL

PART#	SWAGE TYPE	CABLE SIZE	THREAD SIZE	HOLE DIA (EØ)	HOLE SPAN (H) †	FLANGE WIDTH (W)	BODY LENGTH (BL)	BODY DIA (BØ)	LENGTH CLOSED (OPEN) (L)
3278	MACHINE	1/8"	1/4-28	1/4"	1-3/8"	5/8"	4-1/2"	7/16"	7" (10")
3277	MACHINE	3/16"	1/4-28	1/4"	1-3/8"	5/8"	4-1/2"	7/16"	7-1/2" (10-1/2")
3338	MACHINE	1/4"	5/16-24	5/16"	1-1/2"	3/4"	5-1/8"	1/2"	8-1/4" (12")
3275	CABLECRIMP	1/8"	1/4-28	1/4"	1-3/8"	5/8"	4-1/2"	7/16"	7-3/4" (10-3/4")
3276	CABLECRIMP	3/16"	1/4-28	1/4"	1-3/8"	5/8"	4-1/2"	7/16"	8" (11")

† SINCE FLANGES ARE FORMED PIECES, ALLOW A TOLERANCE OF ±1/16" ON FLANGE HOLE SPAN DIMENSION (H).

CableRail Reference Drawing:
SURFACE MOUNT TURNBUCKLE

THIS DRAWING IS THE PROPERTY OF FEENEY INC. ANY REPRODUCTION OF THIS DOCUMENT WITHOUT THE EXPRESSED WRITTEN CONSENT OF FEENEY INC. IS STRICTLY PROHIBITED.

DATE: 05/15/13
 PAGE: 1 of 1
 REV: B (12/08/17) MRJ
 BY: DSY
 CHK: BWA

feeney 

2603 Union St., Oakland, CA 94607
 P: 800-888-2418 F: 510-893-9484
 www.feeneyinc.com