

QUICK-CONNECT[®] INSET: STEEL PIPE POST WITH ANGLED TERMINATION - STAIRS

NOTE: DETAIL IS TYPICAL FOR 1/8", 3/16" AND 1/4" DIAMETER CABLERAIL KITS.

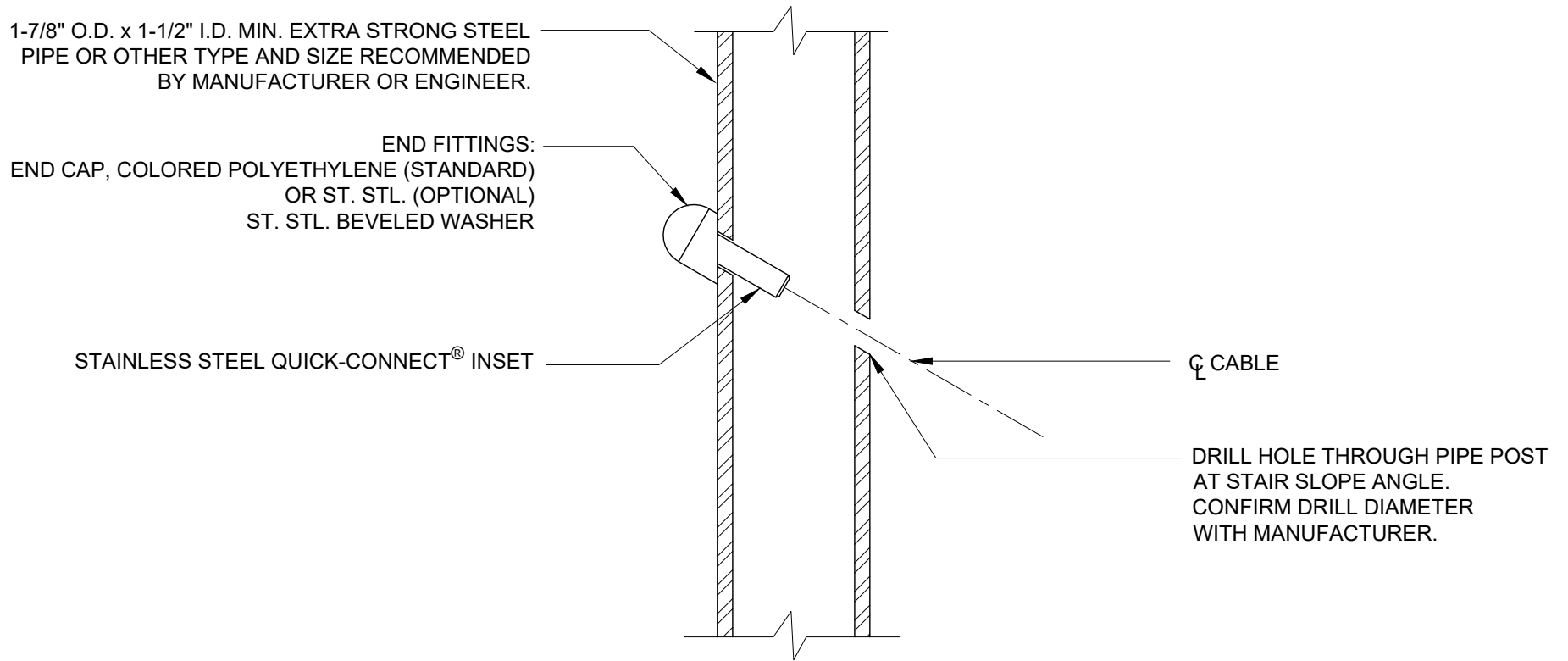

CableRail Reference Drawing:
QUICK-CONNECT[®] FITTING IN STEEL POST AT STAIRS

THIS DRAWING IS THE PROPERTY OF FEENEY INC. ANY REPRODUCTION OF THIS DOCUMENT WITHOUT THE EXPRESSED WRITTEN CONSENT OF FEENEY INC. IS STRICTLY PROHIBITED.

DATE:	05/15/13
PAGE:	1 of 1
REV:	B - 12/06/17 (MRJ)
BY:	DSY
CHK:	BWA

feeney 

2603 Union St., Oakland, CA 94607
P: 800-888-2418 F: 510-893-9484
www.feeneyinc.com