

ITEM: CAP END TURNBUCKLE

MATERIAL: TYPE 316 STAINLESS STEEL.

FITTING TYPE: ADJUSTABLE CABLE END TURNBUCKLE FOR ATTACHING & TENSIONING LINES.

SWAGE TYPE: MACHINE HEX SWAGE AT FACTORY (1/8" & 3/16" SIZES ALSO AVAILABLE IN CABLECRIMP HAND SWAGE STYLE FOR ATTACHING IN THE FIELD).

POST TYPE: METAL. WOOD POSSIBLE BUT NOT RECOMMENDED. (POSTS NOT INCLUDED).

FASTENING TO POST: ATTACH THROUGH END/TERMINATION POST HOLES USING A SCREW-ON END CAP

FASTENING AT ANGLES: DRILL POST HOLES AT ANGLE AND USE BEVELED WASHERS

CABLE TENSIONING: ADJUST BY TURNING TUBULAR TURNBUCKLE BODY.

HARDWARE PAIRINGS: USUALLY PAIRED WITH CAP END OR ANOTHER CAP END TURNBUCKLE. MAY ALSO USE ANY OTHER TENSION ADJUSTMENT FITTING OR FIXED END.

SUPPLIER: FEENEY, INC.

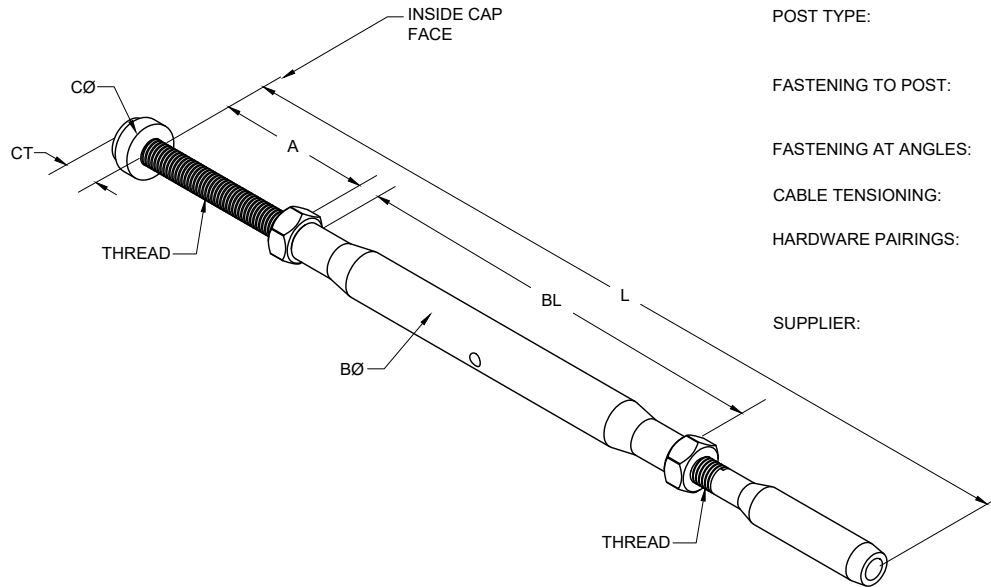

CAP END TURNBUCKLE, STAINLESS STEEL

PART#	SWAGE TYPE	CABLE SIZE	THREAD SIZE	END CAP DIA (CØ)	END CAP THICK (CT)	*SHAFT LENGTH CLOSED (OPEN) (A)	BODY LENGTH (BL)	BODY DIA (BØ)	LENGTH CLOSED (OPEN) (L)	ATTACHMENT POST DRILL HOLE Ø
3325	MACHINE	1/8"	1/4-28	9/16"	5/16"	1-3/8" (3")	4-1/2"	7/16"	7-3/4" (10-3/4")	5/16"
3326	MACHINE	3/16"	1/4-28	9/16"	5/16"	1-3/8" (3")	4-1/2"	7/16"	8-1/4" (11-1/4")	5/16"
3327	MACHINE	1/4"	5/16-24	9/16"	5/16"	3" (5")	5-1/8"	1/2"	10-1/2" (14-1/4")	3/8"
3328	CABLECRIMP	1/8"	1/4-28	9/16"	5/16"	1-3/8" (3")	4-1/2"	7/16"	8-1/2" (11-1/2")	5/16"
3329	CABLECRIMP	3/16"	1/4-28	9/16"	5/16"	1-3/8" (3")	4-1/2"	7/16"	8-3/4" (11-3/4")	5/16"

*LONGER SHAFT LENGTHS ARE AVAILABLE AS A SPECIAL ORDER

CableRail Reference Drawing:
CAP END TURNBUCKLE

THIS DRAWING IS THE PROPERTY OF FEENEY INC. ANY REPRODUCTION OF THIS DOCUMENT WITHOUT THE EXPRESSED WRITTEN CONSENT OF FEENEY INC. IS STRICTLY PROHIBITED.

DATE: 05/15/13
PAGE: 1 of 1
REV: A (12/13/17) MRJ
BY: DSY
CHK: BWA

feeney 
2603 Union St., Oakland, CA 94607
P: 800-888-2418 F: 510-893-9484
www.feeneyinc.com